

Inventions Hong Kong

3rd ASIA EXHIBITION OF INNOVATIONS AND INVENTIONS HONG KONG

第三屆亞洲創新發明展覽會 - 香港

THE ASIA'S UNIQUE ANNUAL INNOVATION & INVENTION EXHIBITION
亞洲年度創新發明展覽

7 - 8 December 2023 | 2023 年 12 月 7 日至 8 日

Entrepreneur Day | 創業日 @ HKCEC | 香港會議展覽中心

Organizer



Partnered with



Collaborating organization



REGISTRATION DEADLINE: 截止報名日期：

30th September 2023 | 2023 年 9 月 30 日

After this date, entry fees will be increased by 10%

在此日期之後，註冊費將增加 10%

The Hong Kong Exporters' Association

Room 924, Star House, 3 Salisbury Road, Tsimshatsui, Kowloon, Hong Kong

T +852 2730 9851 E exhibition@exporters.org.hk

W hkexporters.org.hk

Contact Person: Ms. Vicky Cheung

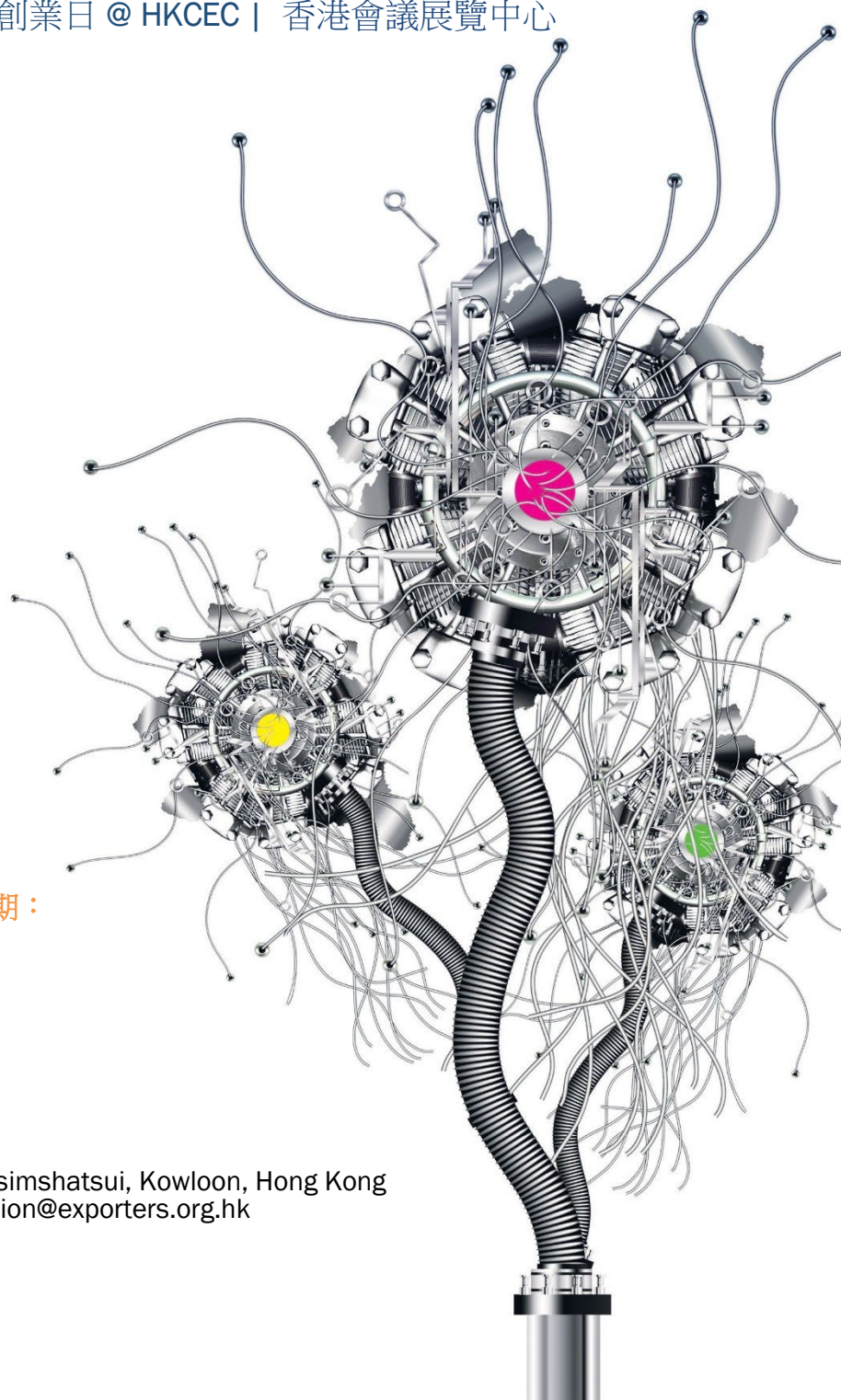

THE ASIA'S UNIQUE ANNUAL INNOVATION & INVENTION EXHIBITION 亞洲獨一無二的年度創新發明展覽

The Asia Exhibition of Innovations and Inventions Hong Kong (AEII) is the Asia's annual exhibition cum competition exclusively devoted to innovations and inventions from Asia to be hosted in Hong Kong, by partnering with Palexpo, Geneva, organizer of the International Exhibition of Inventions Geneva.

亞洲創新發明展覽會 - 香港 (AEII) 是亞洲年度創新發明比賽暨展覽，並與國際著名的日內瓦國際發明展覽會(The International Exhibition of Inventions of Geneva)主辦機構日內瓦 Palexpo 聯合舉辦，旨在展示來自亞洲的創新發明。

Under the innovation-driven development strategy by the Government, Hong Kong aims to enhance its transformation into a knowledge-based economy, by taking the city's strength as an innovation and technology hub in the Asia-Pacific region as well as its key role in the Guangdong-Hong Kong-Macao Greater Bay Area. Out of the Area 86 million population and collective GDP reaching US\$1.79 trillion, Hong Kong is the most open and international city, not only for its well-developed finance system, transportation, trade centre and aviation hub, but also its renowned professional services. These advantages foster Hong Kong as a hub that provides the infrastructure and talent for innovations and collaborations.

在政府創新推動發展策略的帶動下，香港能夠進一步把握其作為亞太地區創新及科技樞紐，以及在粵港澳大灣區重要角色的優勢，進一步強化令香港穩步轉型，朝向知識型經濟體系發展。粵港澳大灣區擁八千六百萬人口，國內生產總值 (GDP) 高達到 1.79 萬億(兆)美元，當中香港是高度開放和國際化的城市，不單擁有完善的金融和交通體系、貿易和航空中心，同時亦能提供優質的專業服務。憑着以上的優勢，有助香港打造成為創科及協作提供基建和培育人才的樞紐。

After 3 years, the event is finally back to Hong Kong physically. Riding on the success the events in 2018 and 2019, and under the advocate of government policies, AEII 2023 will once again be the spotlight on best innovations and inventions uniquely from Asia. Through exhibition and competition under one roof, global experts, inventors in industry will showcase their breakthrough and versatile inventions and solutions to the world. Along with HKTDC events, the Entrepreneur Day (7 - 8 December) and the Business of IP Asia Forum (7 - 8 December) will generate synergy to benefit the community for valuable idea exchanges and unlimited new opportunities.

相隔 3 年，實體展覽會終於載譽歸來。藉著 2018 和 2019 年活動成功舉辦，加上政府政策的提倡下，第三屆亞洲創新發明展覽會在 2023 年將再次成為亞洲獨一無二的創新發明焦點。通過展覽和比賽，結合全球專家及發明家並向全世界展出突破性和多樣化的發明和技術方案。聯同香港貿發局的活動，包括創業日 (12 月 7 日至 8 日) 及亞洲知識產權營商論壇 (12 月 7 日至 8 日)，將覆蓋不同範疇，產生協同效應，有助業界意見交流，帶來無限新機遇。

WHY TO EXHIBIT 參展原因

Show your invention, new product or new technique, your capabilities, your activities and your services to the potential investors and buyers.

向潛在投資者和買家展示您的發明，新產品或新技術，您的能力，您的活動和服務。

Turn your investments into profit by protecting and developing your invention through the negotiation of licenses.

通過許可協商保護和拓展您的發明，將您的投資轉化為利潤。

Meet and make fruitful contacts with manufacturers, commercial agents, promoters, financiers, users and entrepreneurs of all kinds, both national and international.

與國內外各類製造商、代理商、發起人、金融家、用戶和企業家會面並建立聯繫。

Publicize The fruits of your research to business visitor, journalists and the public at large in order to hasten their acceptance on the marketplace. Grasp every opportunity that the biggest specialized event devoted entirely to innovations and inventions can offer.

向商務參觀者，記者和廣大公眾宣傳您的研究成果，以加速他們在市場上的認受性。抓住每一個在創新發明活動所提供的機會。

Media Exposure Benefit from the spin-off of the substantial publicity budget which the exhibition earmarked in different media exposure and activities.

在展覽期間不同媒體曝光和活動的大量宣傳中獲益。

Recognition Professional Jury group will judge each invention exhibited and will select a number of them for awards. The awards given will eloquently certify the merit of the winning inventions and will be a substantial help in commercial launching.

專業評審團將評審展出的每一項發明，並將選出得獎者。所頒發的獎項將證明獲獎發明的優勝之處，並為發明商業化作出重要幫助。

WHO SHOULD EXHIBIT? 誰應該參展？

| manufacturing and commercial companies/enterprises

| startups | inventors and private researchers |

consultancies | laboratories | universities | research

institutions | patent brokers and promoters of

innovation | associations and similar bodies | service

and financial organizations | publishers | regional,

national and international organizations.

製造和商業公司或企業 | 初創公司 | 發明家和私人

研究人員 | 諮詢 | 實驗室 | 大學 | 研究機構 | 專利和

創新推動者 | 協會和相關機構 | 服務和金融組織 | 出

版商 | 區域，國家和國際組織



AWARDS | 獎項

The International Jury comprised of 30+ specialists will judge the inventions and awarded the following Awards:

由 30+位專家組成的國際評審委員會將對發明進行評判，並頒發以下獎項:

- **Grand Award | 大獎**
- **Geneva Invention Award | 日內瓦發明大獎**
- **Gold Medal | 金獎**
- **Silver Medal | 銀獎**
- **Bronze Medal | 銅獎**



Venture Capital Award and **IFIA Award** will be selected from the above awardees by a group of veteran venture capitalists and angel investors to recognize the most worthy investable invention.

創投大獎 與及 **IFIA 大獎** 將由一群資深風險資本家和天使投資者從上述獲獎者中選出，以表彰最值得投資發明。

ENTRY FORM 參加表格

To be returned not later than **30th September**

請於 9 月 30 日前提交

The Hong Kong Exporter's Association 香港出口商會
Room 924, Star House, 3 Salisbury Road,
Tsimshatsui, Kowloon, Hong Kong
香港九龍尖沙咀梳士巴利道 3 號星光行 924 室
Tel. 852 2730 9851 - Fax 852 2730 1869
E: exhibition@exporters.org.hk

REGISTRATION DEADLINE

截止報名日期

30th September 2023 | 2023 年 9 月 30 日

After this date, entry fees will be increased by 10%
在此日期之後，註冊費將增加 10%

Important

- ◆ All Information must be supplied in **English** unless otherwise stated 除註明外，所有資料請以**英文**填寫
- ◆ Entry for "Company Name in English" will appear on the fascia board at your booth 公司名稱將用作攤位之公司招牌

EXHIBITOR INFO | 參展商資料

A. Company Information 公司資料

- 1a. Company Name in English _____
- 1b. 中文公司名稱 (if any) _____
2. Registered Office Address _____
公司登記地址 _____
- Correspondence Address _____
通訊地址 _____
- Same as above 同上
3. Tel No. 電話 _____ 4. Fax No. 傳真 _____
5. Email 電郵 _____ 6. Web-Site 網址 _____
7. No. of Employees 僱員數目 : In Hong Kong 香港 _____ Outside Hong Kong 境外 _____
8. No. of Factory Worker 工人數 In Hong Kong 香港 _____ Outside Hong Kong 境外 _____

B. Information of Contact Person for this Event 是項活動之聯絡人資料

- 1a. Name Mr / Ms _____ 2. Position 職位 _____
(名 First Name) (姓 Last Name)
- 1b. 中文姓名 _____ 先生/小姐/ 3. Direct Tel No. 直線電話 _____
4. Email 電郵 _____ 5. Mobile No. 手提電話 _____

<IMPORTANT> Please provide a valid email address so that we can reach you easily and timely.
請確保以上填寫的電郵為常用及有效，主辦單位日後會以電郵方式與貴司聯繫。

INVENTION | 發明

All Information must be supplied in **English** 所有資料請以**英文**填寫

A. Company Description 公司簡介

This information will be shown in the Official Exhibition Catalogue 此資料將在官方展覽目錄中刊出
(Maximum 50 words (NOT CHARACTERS) | 最多 50 字)

B. About your invention 有關您的發明

This information will be shown in the Technical Notice at your booth for Judging purpose and all publications/certificates of the event

此資料將在攤位上展示用作評審用途及是次活動所有的印刷品/証書

1. Your Invention Name 您的發明名稱

2. If the Jury gives a prize to this invention, to whom should it be awarded? (Please select only ONE option)

如果評委會對這項發明給予獎勵，應該向誰頒發獎項？(請選擇一項)

This invention is invented under company, please use my company name stated at Part A of "Exhibitor Info" as "Inventor"

這項發明是屬於公司名義，請使用「參展商資料」內的公司名稱作為發明者

Please use below Name as "Inventor" (Limited to 2 Names only)

這項發明是屬於個人名義，請使用以下名稱作為發明者 (只限兩個發明者名字)

Inventor Name 1	Mr / Ms	Position 職位
發明者一名稱	(名 First Name) (姓 Last Name)	_____

中文姓名	先生/小姐/	Mobile No. 手提電話
_____	_____	_____

Email 電郵	_____	_____
----------	-------	-------

Inventor Name 2	Mr / Ms	Position 職位
發明者二名稱	(名 First Name) (姓 Last Name)	_____

中文姓名	先生/小姐/	Mobile No. 手提電話
_____	_____	_____

Email 電郵	_____	_____
----------	-------	-------

3. Description of your Invention 發明簡介

This information will be shown in the Technical Notice at your booth for Judging purpose

此資料將在攤位上展示用作評審用途

(Maximum 50 words (NOT CHARACTERS) | 最多 50 字)

C. In which class do you consider your invention should be placed? (Please select ONE class only)
您認為您的發明屬於哪一個類別？(請選擇一項)

*** The class may change subject to Jury's decision 評審有可能更改所屬類別**

Class 類別 A

Smart City – Infrastructure – Building -Artificial Intelligence -
Protection of the environment – Energy

智慧城市 - 基建 - 建築 - 人工智能 - 環境保護 - 能源

Class 類別 B

Smart Home & Living – Wellness Equipment & Appliances, Textile
智能家居與生活 - 健康設備 - 紡織

Class 類別 C

Smart Finance – Fintech - Blockchain & DLT – RegTech –
Electronics - Computer sciences – Software

智能金融 - 金融科技 - 區塊鏈和 DLT – RegTech - 電子 - 計算
機科學、軟件

Class 類別 D

Health Technologies and Medicine – Accessories – Internet of
Medical Technology IoMT & MedTech

健康技術及藥物 - 配件 - 醫療技術互聯網 IoMT 和 MedTech

Class 類別 E

Smart Transportation – Drones and Applications –
Autonomous Transport – Motor vehicles - Ships – Aviation –
Accessories

智能交通 - 無人機和應用 - 自主運輸 - 機動車 - 船 - 航空 - 配件

Class 類別 F

Smart Industry – Mechanics – Agriculture -Processing – Machinery
Tools – Materials

智能工業 - 機械 - 農業 - 加工 - 機械工具 - 物料

D. In what form do you intend to exhibit your invention? 您打算以什麼形式展示您的發明？

Manufactured Article 製成品

Prototype 原型樣本

Plan 計劃

E. Have you already applied for a patent for your invention? 您是否已申請發明專利？

Yes, applied and protected
是，已申請及受到保護

Yes, applied and under filing/pending
是，已提交申請/待處理

No 否

If not, what kind of protection does your invention have? 如果沒有，您的發明有甚麼的保護？

**F. Have you participants in the International Exhibition of Inventions of Geneva? 您有參加日內瓦國際展覽嗎？
If yes, in which edition? 如果是，在哪個年度？**

Yes 是 in 在 _____

No 否

G. What is the purpose of exhibiting your invention? 發明展示的目的是什麼？

Find distributors? 尋找經銷商？

Grant licences to manufacturers? 向製造商授予許可證？

Contact manufacturers? 聯繫製造商？

Grant licences to distributors? 向經銷商授予許可證？

Find a financial backer/ investor?
尋找金融支持者/投資者？

Sell your patent? 銷售您的專利？

REGISTRATION AND STAND RENTAL FEE

發明的註冊及攤位費用

- (i) The price listed below is for ONE invention only. If you wish to exhibit more than one invention, you must fill in one entry form per invention and a reduction of 10% will be granted on the total registration fees.
以下列出的費用是以每項發明為單位。如果您希望展出多項發明，您必須為每項發明填寫一份參加表格，而總註冊費將減少 10%。
- (ii) HK dollars listed below is only applicable to Hong Kong Exhibitors; other countries exhibitors refers to US dollars.
下列港元的費用僅適用於香港參展商; 其他國家的參展商請參考美元價格。

A. REGISTRATION FEE | 註冊費用

General Application 一般申請	HKD 7,500	USD 1,000
-----------------------------	-----------	-----------

+

B. STAND RENTAL FEE | 攤位費用

Panel Booth 小組攤位	HKD 10,000#	USD 1,335#
---------------------	-------------	------------

Application after 30 September 2023 will be subjected to 10% surcharge
2023 年 9 月 30 日之後的申請將收取 10% 的附加費

Total Amount payable Fees (A+B) 參加費的總金額 (A+B)		
--	--	--

Please submit the completed entry form via email: exhibition@exporters.org.hk and send the fee to the following address. Please state at your email if you need an invoice from us. (Cheque payable to "The Hong Kong Exporters' Association", FPS ID [Bank HSBC]: 105483408)

請把已填妥之參加表格電郵至 exhibition@exporters.org.hk 並將參加費用遞交至本會。如需要發票請於電郵註明。(支票抬頭為：香港出口商會, FPS ID [匯豐銀行]: 105483408)

Address: Rm. 924, Star House, 3 Salisbury Rd., Tsimshatsui, Kowloon, HK
地址: 九龍尖沙咀梳士巴利道三號星光行九二四室

We (Name of Company)公司名稱 _____
hereby apply to participate in the Event and/or Exhibition. We understand that the Entry Fee is non-refundable and agree to be bound by the provisions of all documents forming part of the Entry Form, including but not limited to, the attached Conditions of Participation.

We hereby declare that the information given in the entry form is true and correct to the best of our knowledge. We understand that any false or misleading information given by us to the Association will lead to the rejection of our right to participate in the Event and/or Exhibition.

We understand that above information will be included into the Association's databank and the Association can make use of our information for trade promotion purposes.

Company Stamp & Authorized

Signature

公司印章及負責人簽署

Date

日期

Full Name of Authorized Signer

負責人姓名

Position

職位

HOW TO EXHIBIT YOUR INVENTION | 如何展示你的發明

Your invention can be exhibited as : 您的發明可以以下列模式展出

- a pre-series sample 預覽系列樣品
- a commercial sample 商業樣品
- a prototype 原型
- a model 模型
- a plan, drawing, photo or descriptive text 計劃，繪圖，照片或描述性文字

We shall place on your stand: 我們將放在你的攤位上：

- a technical notice (measuring 21 x 17 cm) giving a brief description of your invention in English 技術說明（尺寸為 21 x 17 厘米），用英文簡要介紹您的發明。

Panel Booth 小組攤位

*Diagram for reference only 圖片只供參考

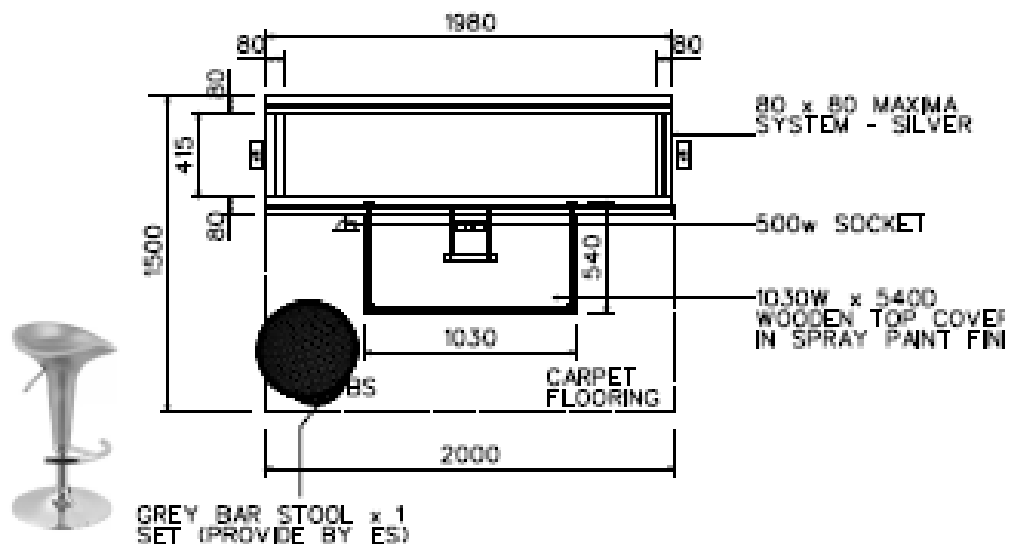

If you want to order additional furniture, or electricity supply on your stand, please contact us at your earliest convenience.

如果您希望在您的展台增加額外家具或電源，請與我們聯絡。

Conditions of Participation (This Sheet is to be retained by the Exhibitor 本頁由參展商保留)

- Asia Exhibition of Innovations and Inventions Hong Kong is open to inventors, companies, firms, promoters, associations, universities, private and state organizations, showing inventions already protected by intellectual property rights.
亞洲創新發明展覽會 - 香港開放給：發明家、公司、企業、協會、大學、私人及國家組織，展示已受知識產權保護的發明。
 - Each invention may only be presented once at the Asia Exhibition of Innovations and Inventions Hong Kong, unless substantial modifications have been made since it was first exhibited
發明只能在亞洲創新發明展覽會上展出一次，除非自首次展出以來對其進行了大量修改。
 - Inventions may be presented in the form of pre-series or commercial samples, already manufactured articles, prototypes, models, plans, drawings, photos and texts.
發明可以以預覽系列樣品或商業樣品、已製造的物品、原型、模型、計劃、圖紙、照片和文本的形式呈現。
 - The inventions exhibited will be grouped by class. Exhibitors must indicate the kind of stand they need on the entry form. Final stands and booth location will be decided by the Organizer.
展出的發明將按類別分組。參展商必須在報名表上註明他們需要的展台類型。展台類型和展台位置將由主辦單位作最後決定。
 - In the Official Catalogue, the inventions will be published in one of the following classes and the Organizer alone shall decide in which classes they shall be placed:
在官方目錄中，發明將在下列類別之一中發布，主辦單位再作決定項目應屬於哪一個類別
- | |
|--|
| ClassA Smart City –Infrastructure – Building -Artificial Intelligence - Protection of the environment - Energy
智慧城市 - 基建 - 建築 - 人工智能 - 環境保護 - 能源 |
| ClassB Smart Home & Living – Wellness Equipment & Appliances, Textile
智能家居與生活 - 健康設備 - 紡織 |
| ClassC Smart Finance –Fintech - Blockchain & DLT – RegTech – Electronics - Computer sciences - Software
智能金融 - 金融科技 - 區塊鏈和 DLT – RegTech - 電子 - 計算機科學、軟件 |
| ClassD Health Technologies and Medicine – Accessories – Internet of Medical Technology IoMT & MedTech
健康技術及藥物 - 配件 - 醫療技術互聯網 IoMT 和 MedTech |
| ClassE Smart Transportation –Drones and Applications – Autonomous Transport – Motor vehicles - Ships – Aviation - Accessories
智能交通 - 無人機和應用 - 自主運輸 - 機動車 - 船 - 航空 - 配件 |
| ClassF Smart Industry –Mechanics – Agriculture -Processing – Machinery Tools – Materials
智能工業 - 機械 - 農業 - 加工 - 機械工具 - 物料 |
- Exhibitors must complete A SEPARATE ENTRY FORM FOR EACH INVENTION WHICH THEY WISH TO EXHIBIT. Only one invention can be included in each entry form. Entry forms, duly completed and signed, should be sent as soon as possible and before the deadline to the Organizer. After the registration deadline, entry fees will be increased by 10%
參展商必須為每項發明填寫獨立的登記表格。每份表格上不能超過一項發明。填寫完整並簽名確認的報名表應盡快在截止日期前交回秘書處。在截止日期後，註冊費將增加 10%。
 - Once the Entry Form has been accepted and registration confirmed by the Organizer to the exhibitor, the exhibitor is obliged to pay the total amount of invoice within the due date indicated. Exhibitors who cancel their participation before the registration deadline must pay 50% of their invoice. Exhibitors who cancel their participation after the registration deadline must pay the whole amount of their invoice. 一旦參賽表格被主辦單位確認，參展商有義務在指定時間內支付發票總金額。在截止報名日期之前取消參加的公司必須支付 50% 的發票總金額。在截止報名日期後取消參加的公司必須支付全額發票金額。
 - GENERAL INSTRUCTIONS 一般說明**
After receipt the Entry Form, the Organizer will send the General Instructions to each exhibitor. General Instructions concerning: - The dates for building and dismantling the stands - How to send and/or transport the inventions - The official opening ceremony of the Exhibition- The day on which the International Jury examines each invention - The prize-giving ceremony.
在收到報名表後，主辦單位將向每個參展商發送須知。一般須知的內容包括：搭建和拆除展台的日期、發送和/或運送發明項目的指引、展覽的開幕式、評審團評審、頒獎儀式等安排。
 - Exhibitors who require extra electricity supply, furniture, parking or advertising space in the Official Catalogue must submit their requests on the special forms to Organizer within the deadline. 需要額外電力供應、家具、停車場或廣告空間的參展商必須在表格上提交要求，並在截止日期前轉發給主辦單位。
 - A security service will operate during the whole period of the Exhibition. However, the Organizer and its representatives abroad will not be liable for loss, theft, damage due to fire or other causes, or personal injury suffered, during the Exhibition or in transit. Exhibitors should confine their display within the prescribed booth area, so as not to jeopardize fire safety. 整個展覽期間將提供保安服務。但主辦單位及其海外代表不會就因火災或其他原因造成的損失，盜竊，損壞或人身傷害承擔任何責任。各參展商只可在本身的攤位範圍內佈置和擺放展品，不得在會場的公眾地方擺放任何展品，並須保持會場的整潔及注意防火安全。
 - SALE TO OUR VISITORS 銷售給買家**
Selling products or articles to visitors is forbidden. 禁止向參觀者銷售產品或物品。
 - By formal application to participate in the Exhibition, each exhibitor undertakes responsibility to ensure the invention will be arrived to the fairground before the time stated in the instructions and to allow it to display during the whole exhibition. 通過參加展覽的正式申請，每個參展商承諾確保在須知中所述的時間運送發明，並在整個展覽中展示。

The Chinese translation thereof is for reference only and the English version shall always prevail in case of any inconsistency between the English version and the Chinese translation thereof. 中文譯本僅供參考，若中文譯本與英文版本倘有任何抵觸，一切內容概以英文版本為準